



250 Staunton Turnpike, Parkersburg, WV 26104

# 8400 Series Vinyl Horizontal Sliding Window "NON-IMPACT"

### GENERAL NOTES

1. This product has been evaluated and is in compliance with the 8th Edition (2023) Florida Building Code (FBC) structural requirements excluding the "High Velocity Hurricane Zone" (HVHZ).
2. Product anchors shall be as listed and spaced as shown on details. Anchor embedment to base material shall be beyond wall dressing or stucco.
3. When used in areas requiring wind borne debris protection this product is required to be protected with an impact resistant covering that complies with FBC Sections 1609.1.2 & R301.2.1.2.
4. For 2x stud framing construction, anchoring of these units shall be the same as that shown for 2x buck masonry construction.
5. Site conditions that deviate from the details of this drawing require further engineering analysis by a licensed engineer or registered architect.

TABLE OF CONTENTS	
SHEET#	DESCRIPTION
1	Typical elevations, design pressures and general notes
2	Horizontal cross sections
3	Vertical cross sections
4	Buck and frame anchoring
5	Components
6	Bill of materials & glazing details

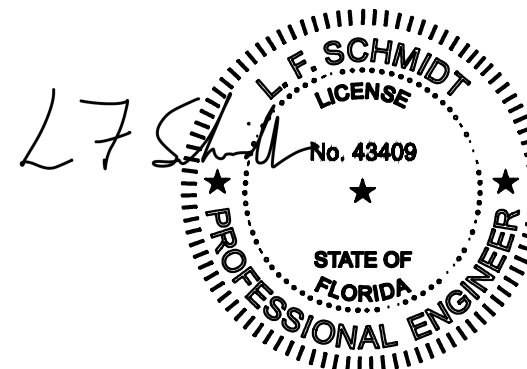

This item has been digitally signed and sealed by L. F. Schmidt, P.E. on the date adjacent to the seal. Printed copies of this document are not considered signed and sealed and the signature must be verified on any electronic copies.

THIS PRODUCT APPROVAL IS VALID ONLY FOR THE STATE OF FLORIDA

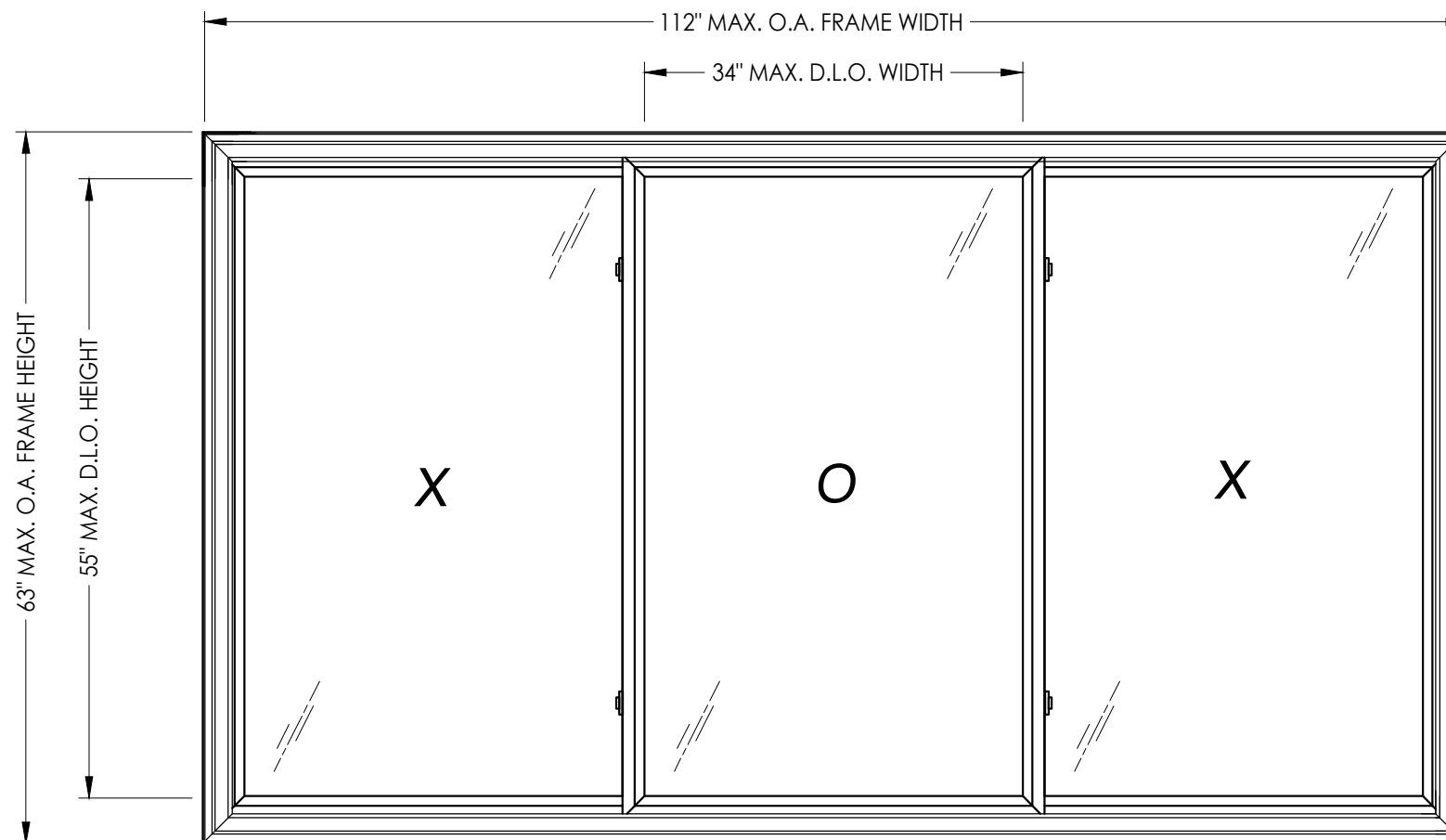

XOX SHOWN  
XXX ALSO APPROVED

MAX. FRAME DIMENSION	MAX. D.L.O. DIMENSION	GLASS TYPE	DESIGN PRESSURE (PSF)	
			POSITIVE	NEGATIVE
110.0" X 62.0"	33.0" X 54.0"	G1	+50.0	-50.0

Documents Prepared By:  
Lyndon F. Schmidt  
P.E. No. 43409

*RW* BUILDING CONSULTANTS, INC.  
P.O. Box 230, Valrico, FL 33595  
Phone No.: 813.659.9197  
FBPE Registry No. 9813

PRODUCT: 8400 SERIES

PART OR ASSEMBLY:  
TYPICAL ELEVATION, DESIGN PRESSURES & GENERAL NOTES

NO.	DATE	REVISIONS
5	7/06/23	UPDATE TO 8TH ED. (2023) FBC
4	7/06/20	UPDATE TO 7TH ED. (2020) FBC
3	6/01/17	UPDATE TO 6TH ED. (2017) FBC
2	1/28/15	UPDATE TO 5TH ED. (2014) FBC
1	4/04/13	ADD COSMETIC FLANGES

DATE: 12/05/12

SCALE: N.T.S.

DWG. BY: JK

CHK. BY: LFS

DRAWING NO.: FL-16092.3

SHEET 1 OF 6

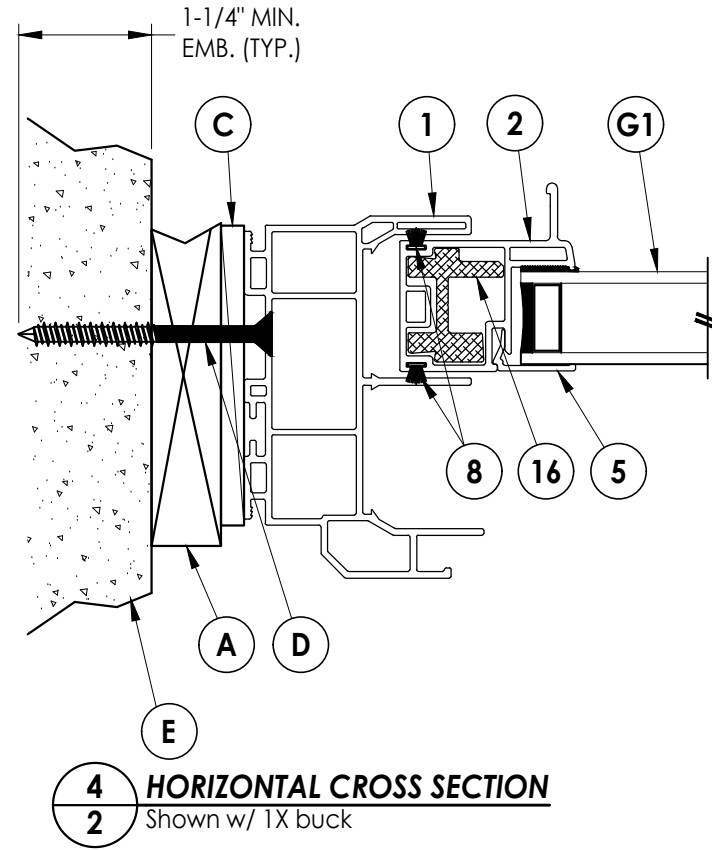
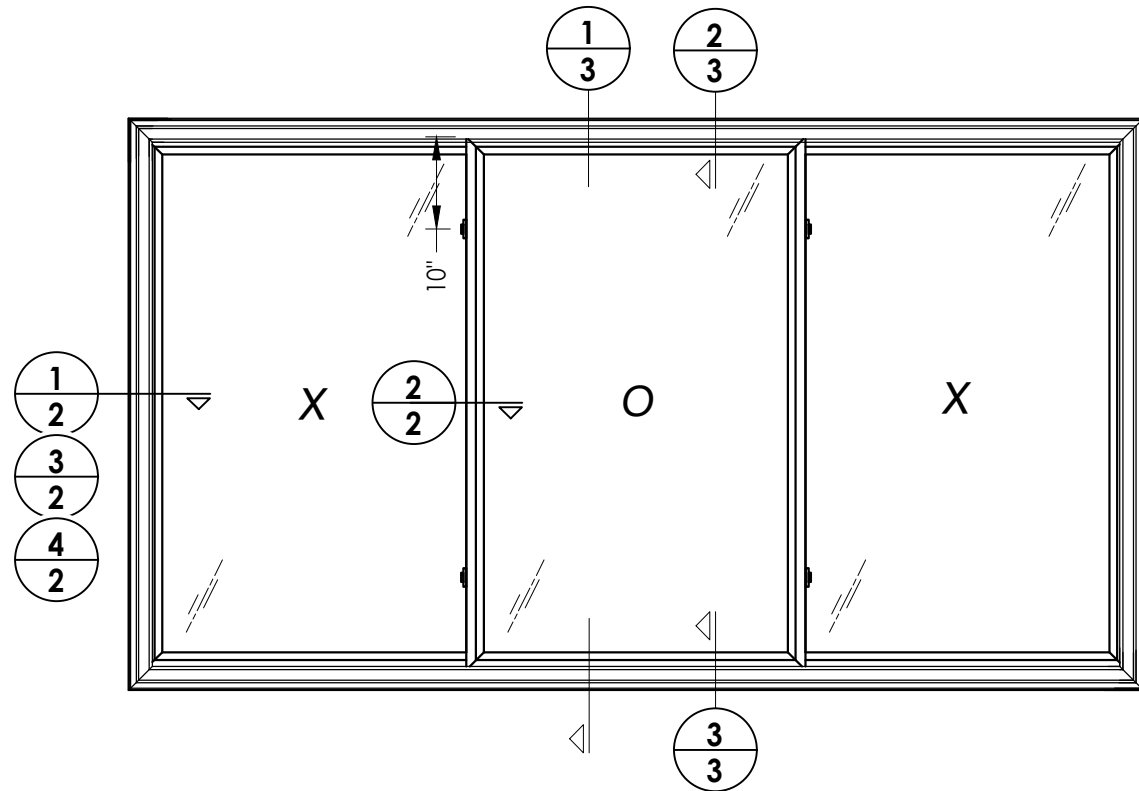

**4** HORIZONTAL CROSS SECTION  
**2** Shown w/ 1X buck

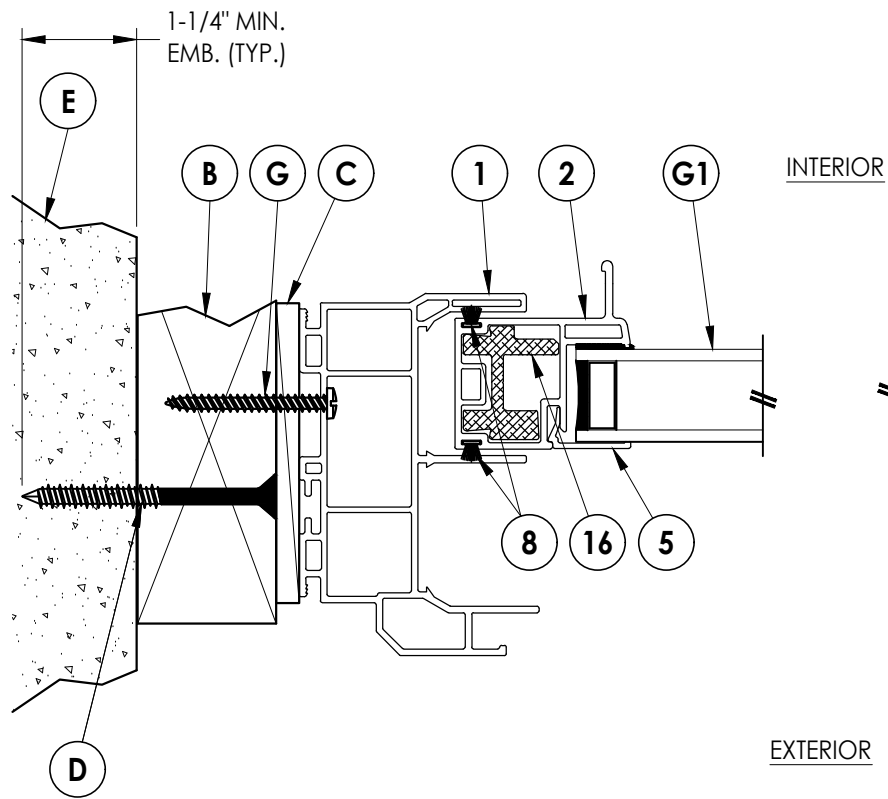

**1** HORIZONTAL CROSS SECTION  
**2** Shown w/ 2X buck

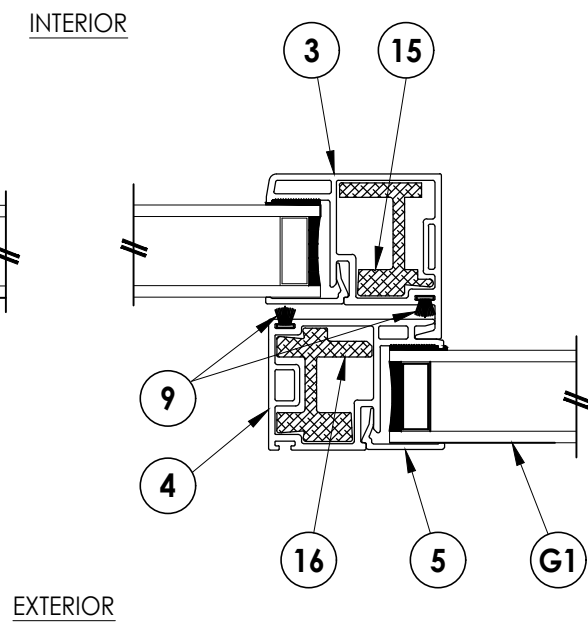

**2** HORIZONTAL CROSS SECTION  
**2** Shown direct to masonry

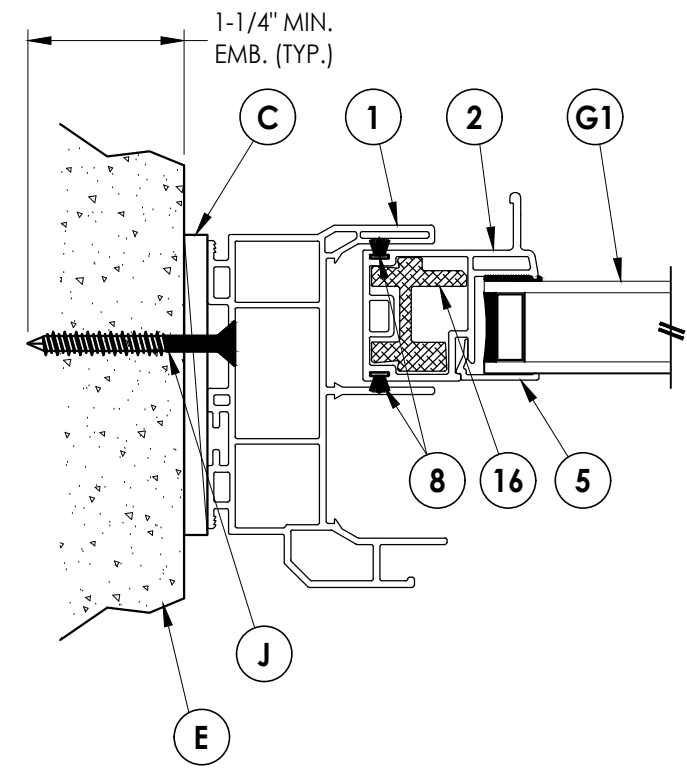

**3** HORIZONTAL CROSS SECTION  
**2** Shown direct to masonry

Documents Prepared By:  
 Lyndon F. Schmidt  
 P.E. No. 43409

**RW** BUILDING CONSULTANTS, INC.  
 P.O. Box 230, Valrico, FL 33595  
 Phone No.: 813.659.9197  
 FBPE Registry No. 9813

PRODUCT: 8400 SERIES  
 PART OR ASSEMBLY: HORIZONTAL CROSS SECTIONS

NO.	DATE	REVISIONS	BY
5	7/06/23	UPDATE TO 8TH ED. (2023)	FBC LFS
4	7/06/20	UPDATE TO 7TH ED. (2020)	FBC LFS
3	6/01/17	UPDATE TO 6TH ED. (2017)	FBC JK
2	1/28/15	UPDATE TO 5TH ED. (2014)	FBC LFS
1	4/04/13	ADD COSMETIC FLANGES	

DATE: 12/05/12  
 SCALE: N.T.S.  
 DWG. BY: JK  
 CHK. BY: LFS  
 DRAWING NO.: FL-16092.3  
 SHEET 2 OF 6

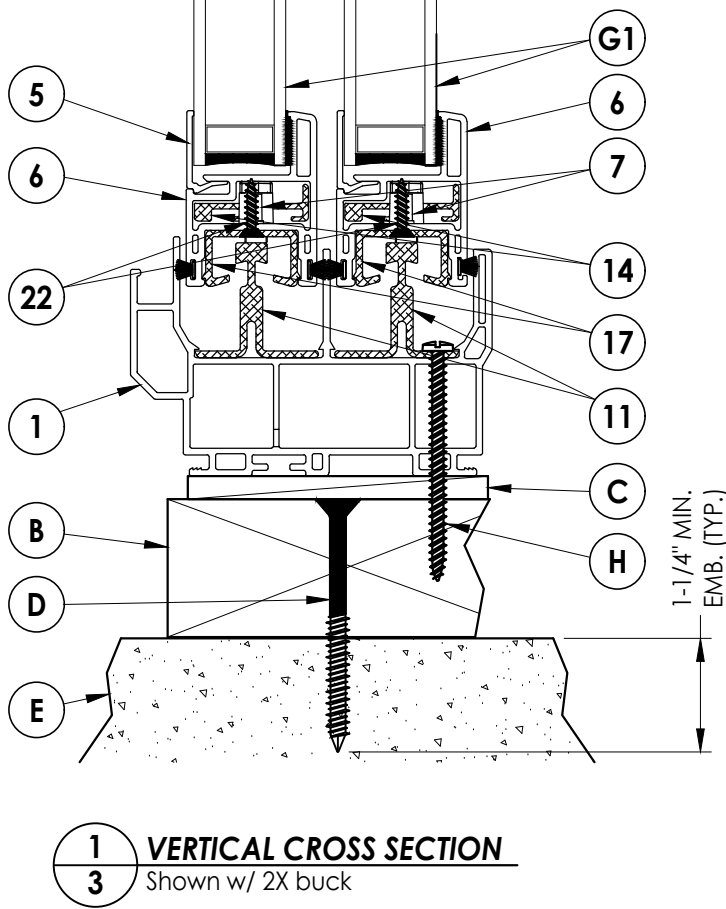
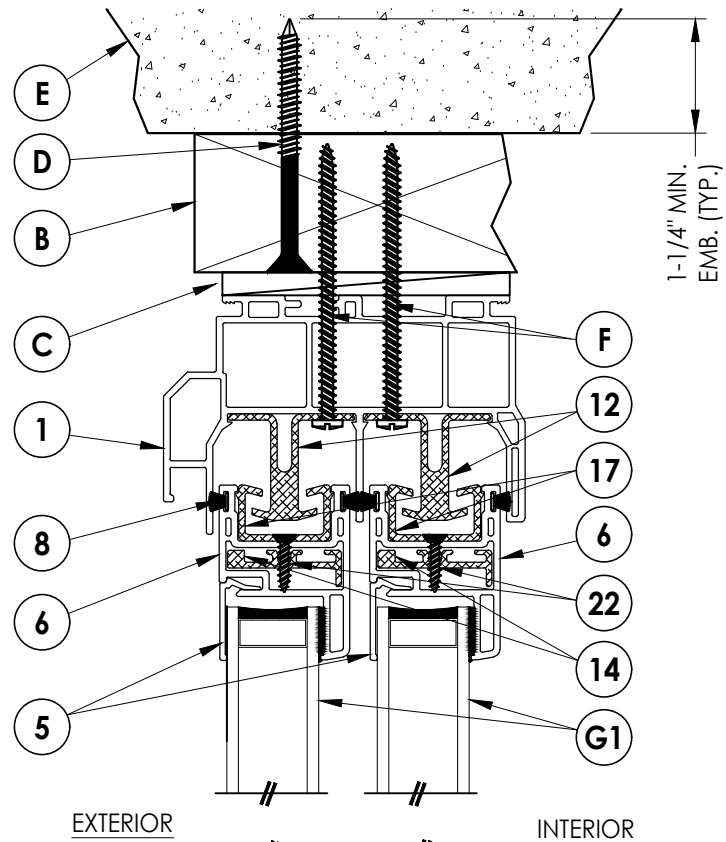

**1 VERTICAL CROSS SECTION**  
3 Shown w/ 2X buck

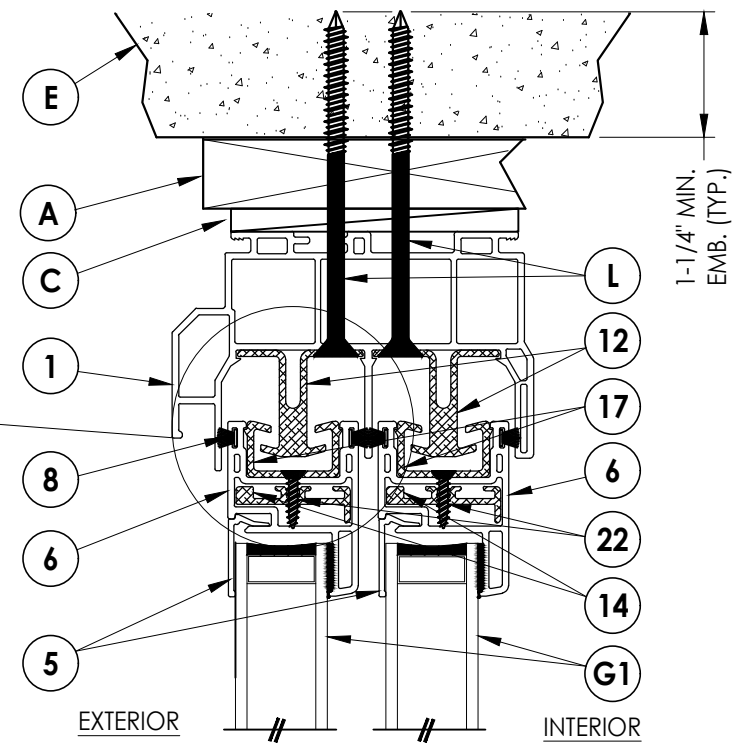
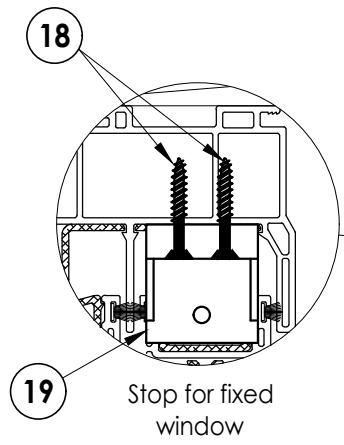

**2 VERTICAL CROSS SECTION**  
3 Shown w/ 1X buck

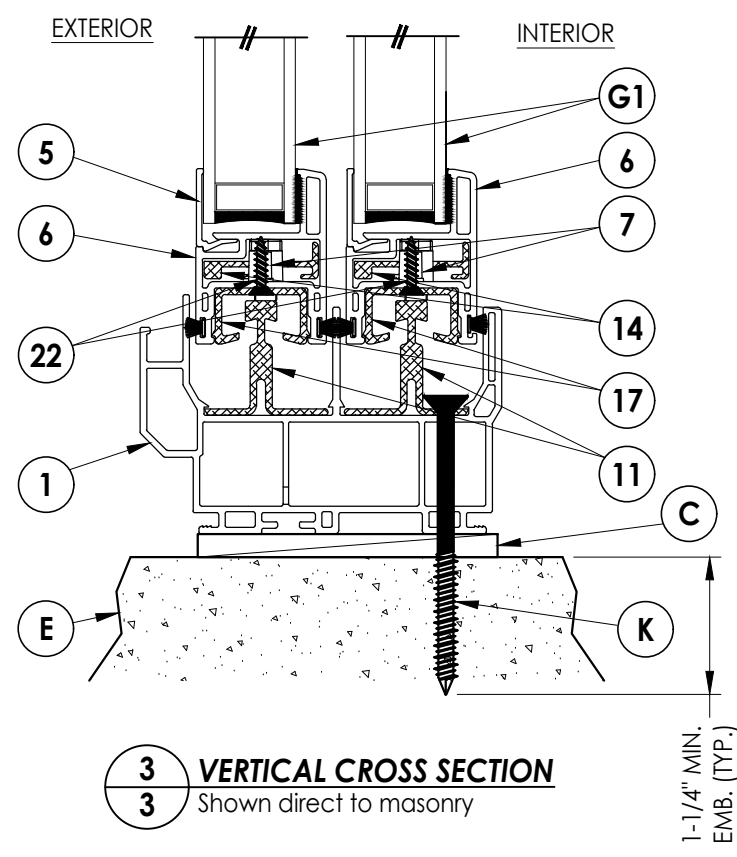

**3 VERTICAL CROSS SECTION**  
3 Shown direct to masonry

Documents Prepared By:  
Lyndon F. Schmidt  
P.E. No. 43409

**RW** BUILDING CONSULTANTS, INC.  
P.O. Box 230, Vairico, FL 33595  
Phone No.: 813.659.9197  
FBPE Registry No. 9813

PRODUCT: 8400 SERIES  
PART OR ASSEMBLY: VERTICAL CROSS SECTIONS

NO.	DATE	REVISIONS	BY
5	7/06/23	UPDATE TO 8TH ED. (2023)	FBC
4	7/06/20	UPDATE TO 7TH ED. (2020)	FBC
3	6/01/17	UPDATE TO 6TH ED. (2017)	FBC
2	1/28/15	UPDATE TO 5TH ED. (2014)	FBC
1	4/04/13	ADD COSMETIC FLANGES	LFS

DATE: 12/05/12  
SCALE: N.T.S.  
DWG. BY: JK  
CHK. BY: LFS  
DRAWING NO.: FL-16092.3  
SHEET 3 OF 6

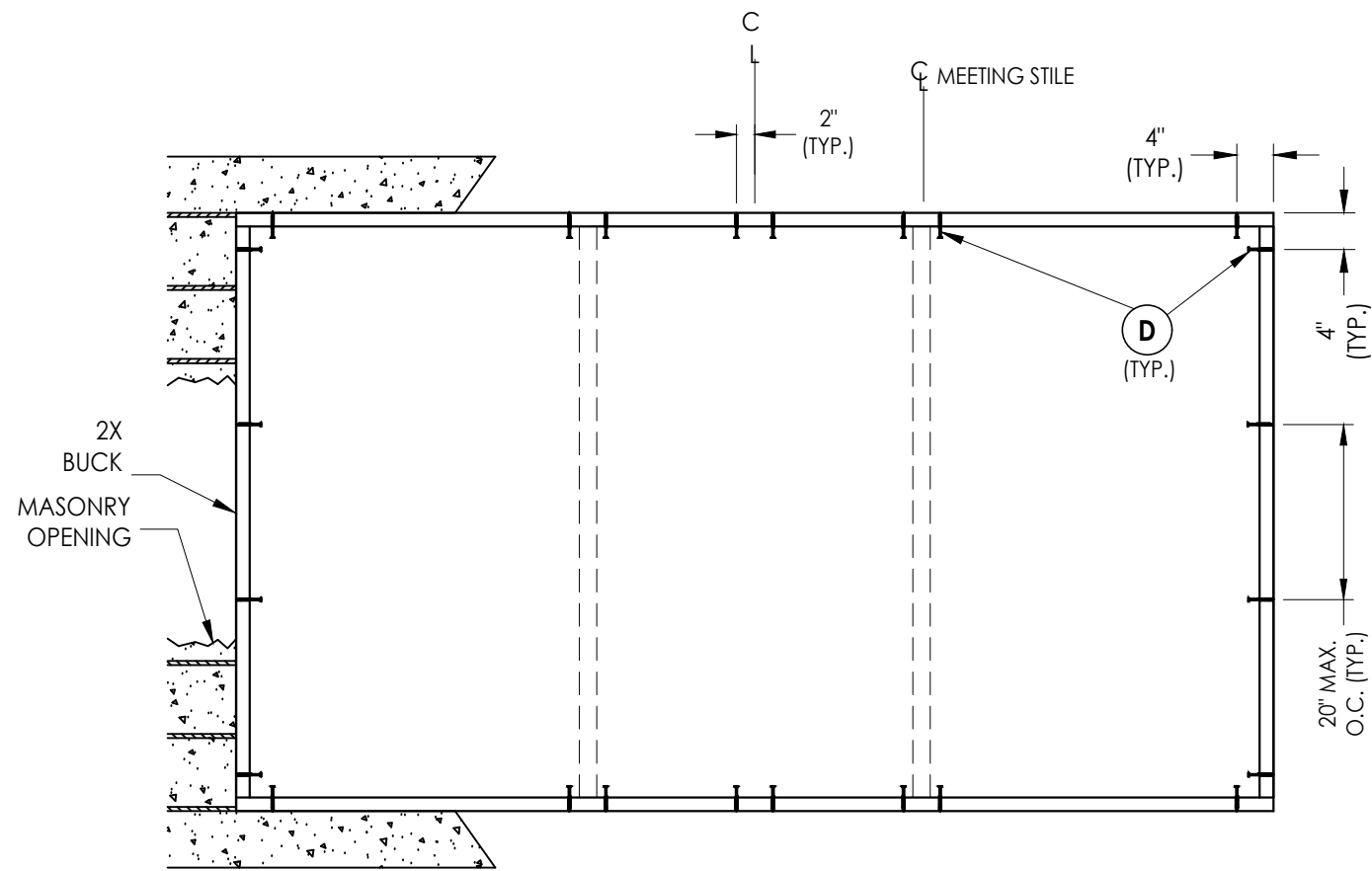

**BUCK ANCHORING**

CONCRETE ANCHOR NOTES:

1. Concrete anchor locations at the corners may be adjusted to maintain the min. edge distance to mortar joints.
2. Concrete anchor locations noted as "MAX. ON CENTER" must be adjusted to maintain the min. edge distance to mortar joints, additional concrete anchors may be required to ensure the "MAX. ON CENTER" dimension are not exceeded.
3. Concrete anchor table:

ANCHOR TYPE	ANCHOR SIZE	MIN. EMBEDMENT	MIN. CLEARANCE TO MASONRY EDGE	MIN. CLEARANCE TO ADJACENT ANCHOR
ITW TAPCON®	1/4"	1-1/4"	2"	4"
DeWALT ULTRACON+®	1/4"	1-1/4"	2-1/2"	3"
HILTI KWIK-CON II+®	1/4"	1-1/4"	2-1/2"	3"

WOOD SCREW INSTALLATION NOTES:

1. Maintain a minimum 5/8" edge distance, 1" end distance, & 1" o.c. spacing of wood screws to prevent the splitting of wood.

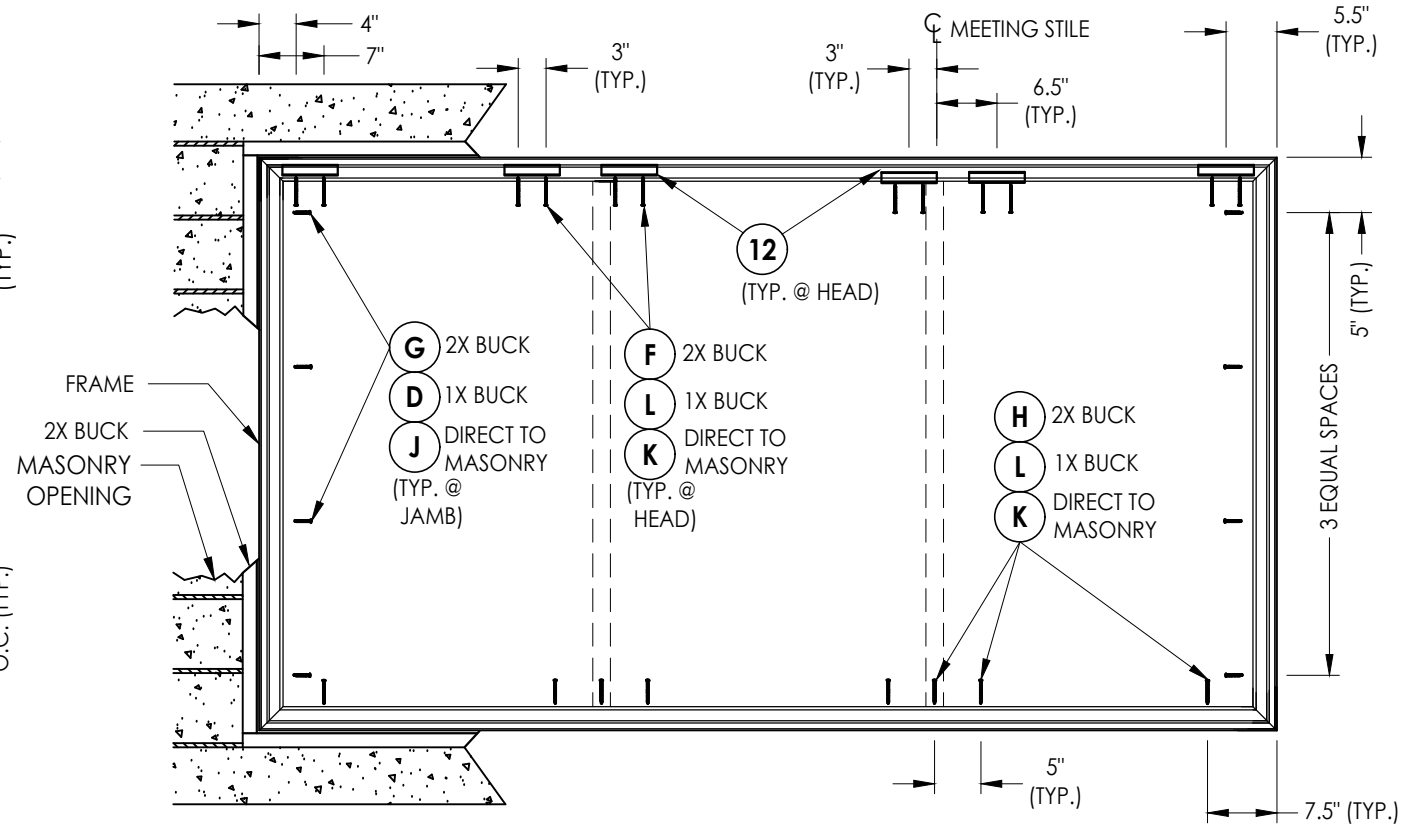

**FRAME ANCHORING**

Documents Prepared By:  
Lyndon F. Schmidt  
P.E. No. 43409

**RW** BUILDING CONSULTANTS, INC.  
P.O. Box 230, Valrico, FL 33595  
Phone No.: 813.659.9197  
FBPE Registry No. 9813

PRODUCT: 8400 SERIES  
PART OR ASSEMBLY: BUCK AND FRAME ANCHORING

NO.	DATE	REVISIONS
5	7/06/23	UPDATE TO 8TH ED. (2023) FBC
4	7/06/20	UPDATE TO 7TH ED. (2020) FBC
3	6/01/17	UPDATE TO 6TH ED. (2017) FBC
2	1/28/15	UPDATE TO 5TH ED. (2014) FBC
1	4/04/13	ADD COSMETIC FLANGES

DATE: 12/05/12  
SCALE: N.T.S.  
DWG. BY: JK  
CHK. BY: LFS  
DRAWING NO.: FL-16092.3  
SHEET 4 OF 6

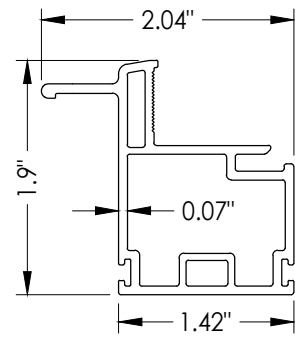

**2 SLIDER PULL STILE**

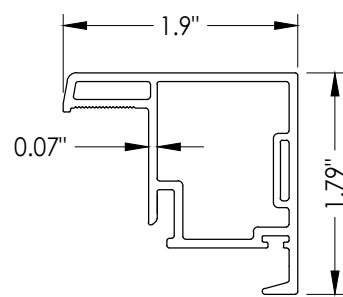

**3 LOCK STILE**

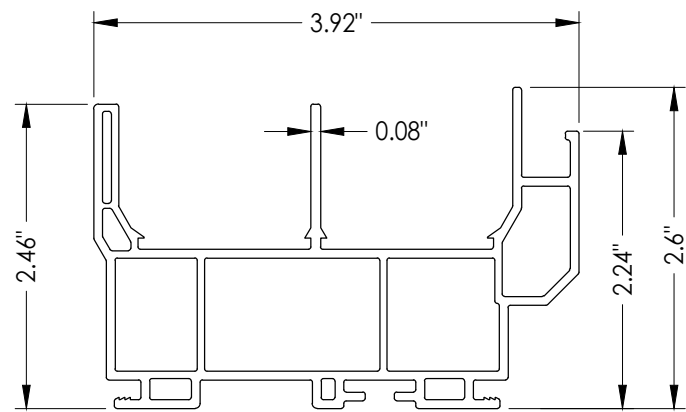

**1 FRAME**

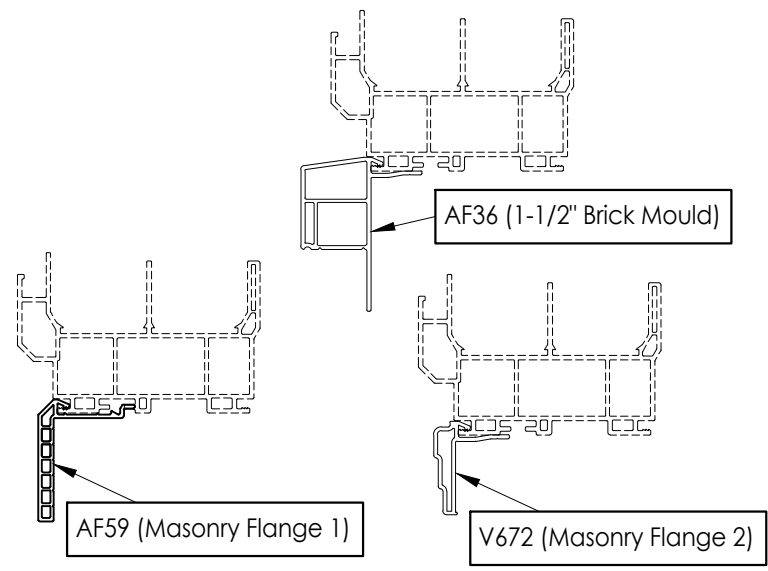

**OPTIONAL COSMETIC FLANGES**

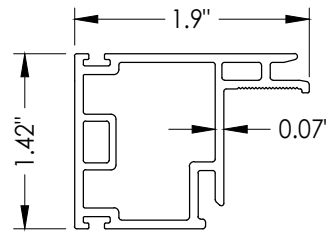

**4 KEEPER STILE**

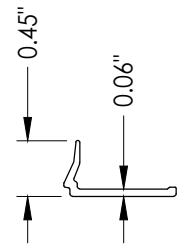

**5 GLAZING BEAD**

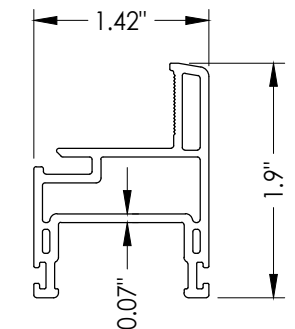

**6 SLIDER COMMON RAIL**

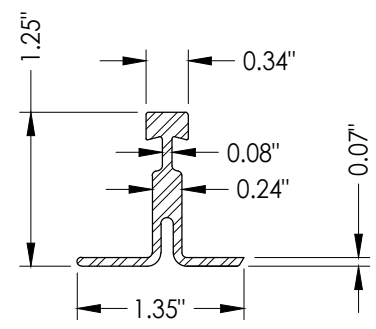

**11 SILL TRACK**  
Full width

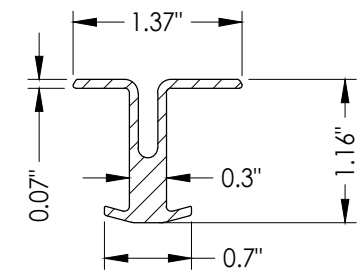

**12 HEAD TRACK**  
6\"/>

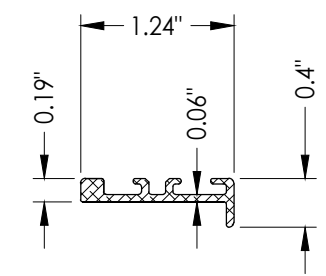

**14 REINFORCEMENT**  
Common Rail

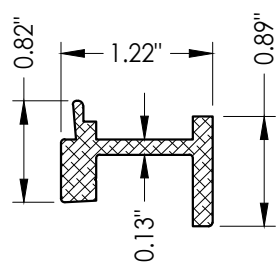

**15 REINFORCEMENT**  
Lock Stile

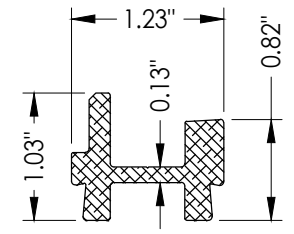

**16 REINFORCEMENT**  
Keeper and Pull Stile

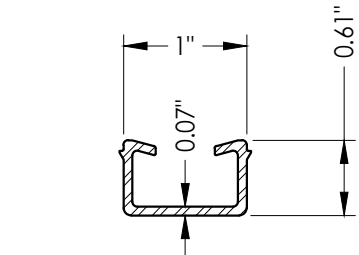

**17 SLIDER SASH RETAINING CLIP**

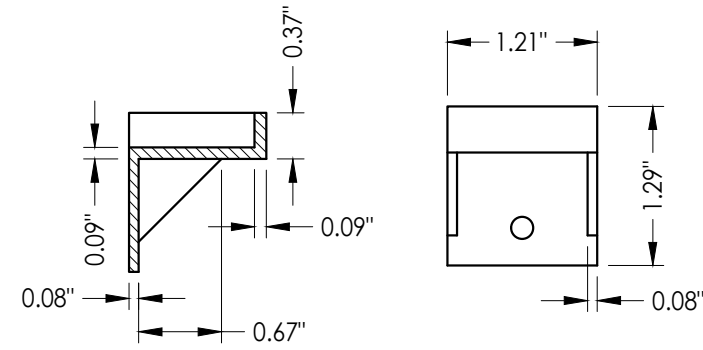

**19 FLANKER STOP**

Documents Prepared By:  
Lyndon F. Schmidt  
P.E. No. 43409

**RW** BUILDING CONSULTANTS, INC.  
P.O. Box 230, Valrico, FL 33595  
Phone No.: 813.659.9197  
FBPE Registry No. 9813

PRODUCT: 8400 SERIES

PART OR ASSEMBLY: COMPONENTS

NO.	DATE	REVISIONS
5	7/06/23	UPDATE TO 8TH ED. (2023) FBC LFS
4	7/06/20	UPDATE TO 7TH ED. (2020) FBC LFS
3	6/01/17	UPDATE TO 6TH ED. (2017) FBC LFS
2	1/28/15	UPDATE TO 5TH ED. (2014) FBC JK
1	4/04/13	UPDATE FRAME SIZE/DP/GLZ LFS

DATE:	12/05/12
SCALE:	N.T.S.
DWG. BY:	JK
CHK. BY:	LFS
DRAWING NO.:	FL-16092.3
SHEET	5 OF 6

**BILL OF MATERIALS**

ITEM #	DESCRIPTION	MATERIAL
A	1X BUCK (SG >= 0.42)	WOOD
B	2X BUCK (SG >= 0.42)	WOOD
C	1/4" MAX. SHIM SPACE	-
D	1/4" X 2-3/4" PFH DeWALT OR ITW CONCRETE SCREW	STEEL
E	MASONRY - 3,000 PSI MIN. CONCRETE CONFORMING TO ACI 301 OR HOLLOW BLOCK CONFORMING TO ASTM C90	CONCRETE
F	#10 X 3" PPH WOOD SCREW (1-3/8" MIN. EMBEDMENT)	STEEL
G	#10 X 1-3/4" PPH WOOD SCREW (1-1/8" MIN. EMBEDMENT)	STEEL
H	#10 X 2-1/2" PPH WOOD SCREW (7/8" MIN. EMBEDMENT)	STEEL
J	1/4" X 2-1/4" ITW CONCRETE SCREW	STEEL
K	1/4" X 3-1/4" ITW CONCRETE SCREW	STEEL
L	1/4" X 3-3/4" ITW CONCRETE SCREW	STEEL
1	FRAME*	PVC
2	SLIDER PULL STILE*	PVC
3	LOCK STILE*	PVC
4	KEEPER STILE*	PVC
5	GLAZING BEAD*	PVC
6	SLIDER COMMON RAIL*	PVC
7	BALL BEARING ROLLER	-
8	WEATHERSTRIP (0.230")	-
9	WEATHERSTRIP (0.380")	-
11	SILL TRACK	ALUM
12	HEAD TRACK	ALUM
14	SLIDE RAIL REINFORCEMENT (6063-T6 ALUM)	ALUM
15	REINFORCEMENT (6005-T5 ALUM)	ALUM
16	REINFORCEMENT (6005-T5 ALUM)	ALUM
17	SLIDER SASH RETAINING CLIP	ALUM
18	#8 X 1" PFH SMS	STEEL
19	FLANKER STOP	NYLON
22	#8 X 5/8" (#6 head) PFH SMS	STEEL

\* THE APPROVED WHITE RIGID PVC EXTERIOR EXTRUSIONS FOR WINDOWS ARE TO BE PRODUCED BY EXTRUDERS LICENSEES IN "AAMA CERTIFICATION PROGRAMS FOR RIGID PVC EXTRUSIONS".

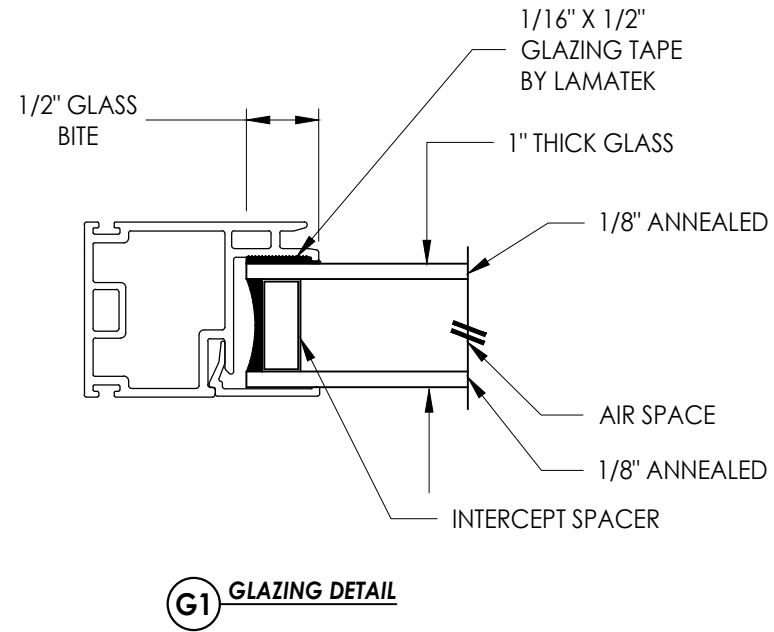

Documents Prepared By:  
Lyndon F. Schmidt  
P.E. No. 43409

**RW** BUILDING CONSULTANTS, INC.  
P.O. Box 230, Vairico, FL 33595  
Phone No.: 813.659.9197  
FBPE Registry No. 9813

PRODUCT: 8400 SERIES

PART OR ASSEMBLY:  
BILL OF MATERIALS  
& GLAZING DETAILS

NO.	DATE	REVISIONS
5	7/06/23	UPDATE TO 8TH ED. (2023) FBC LFS
4	7/06/20	UPDATE TO 7TH ED. (2020) FBC LFS
3	6/01/17	UPDATE TO 6TH ED. (2017) FBC LFS
2	1/28/15	UPDATE TO 5TH ED. (2014) FBC JK
1	4/04/13	ADD COSMETIC FLANGES LFS

DATE: 12/05/12  
SCALE: N.T.S.  
DWG. BY: JK  
CHK. BY: LFS  
DRAWING NO.: FL-16092.3  
SHEET 6 OF 6